

| | |
|------------------------|--------------------------------------|
| DRAWING NUMBER: | 15-266-X-XX |
| PRODUCT GROUP: | TERMINALS |
| SUB-GROUP: | MILITARY NON-INSULATED TERMINALS |
| DESCRIPTION: | NON-INSULATED DOUBLE TURRET TERMINAL |

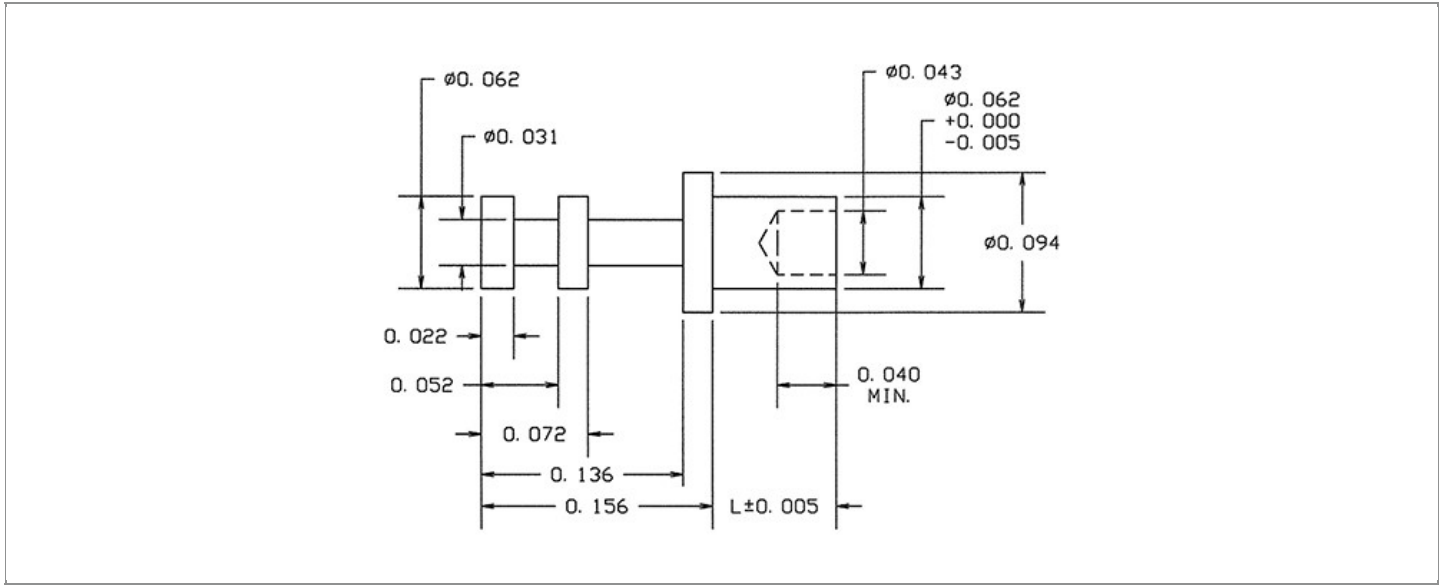

| BOARD / PANEL MOUNTING METHOD | MOUNTING HOLE SIZE | DRILL SIZE | FEED THRU COMBINATION |
|-------------------------------|--------------------|------------|-----------------------|
| SWAGE MOUNT | 0.0635" ± 0.001 | #52 | N/A |

PART NO. STRUCTURE:

15-266 - X - XX
 PART SERIES DIMENSION FINISH

MATERIAL OPTIONS:

15-266-X-XX

| COMPONENT | MATERIAL | MATERIAL AND SPECIFICATION |
|-----------|----------|--|
| TERMINAL | BRASS | BRASS PER ASTM B16, ALLOY C36000, 1/2 HARD |

DIMENSION OPTIONS:

15-266-X-XX

| DIMENSION | K | OVERALL LENGTH | SHANK LENGTH (L) | BOARD/PANEL THICKNESS |
|-----------|-----|----------------|------------------|-----------------------|
| 1 | N/A | 0.209" | 0.053" | 1/32" |
| 2 | N/A | 0.240" | 0.084" | 1/16" |
| 3 | N/A | 0.271" | 0.115" | 3/32" |
| 4 | N/A | 0.303" | 0.147" | 1/8" |

FINISH - PLATING OPTIONS:

15-266-X-XX

| FINISH CODE | COMPONENT | FINISH | FINISH AND SPECIFICATION |
|-------------|-----------|-----------------|--|
| 05 | TERMINAL | ELECTRO-SOLDER | 0.000300"MIN. ELECTRO-SOLDER PER SAE-AMS-P-81728 OVER 0.000100"MIN. COPPER PER SAE-AMS-2418 |
| 088 | TERMINAL | BRIGHT TIN-LEAD | 0.000300"MIN. BRIGHT TIN-LEAD (Sn93%-Pb7%) PER ASTM B545 OVER 0.000100"MIN. COPPER PER SAE-AMS-2418 |
| 095 | TERMINAL | HOT SOLDER DIP | 0.000100"MIN. HOT SOLDER DIP USING Sn60 PER IPC-J-STD-006 OVER 0.000100"MIN. COPPER PER SAE-AMS-2418 |

TOLERANCES:*

| DECIMAL | FRACTIONAL | ANGULAR | DRAWING ORIGATION DATE | LAST MODIFICATION DATE |
|---------|------------|---------|------------------------|------------------------|
| ± 0.005 | N/A | ± 3 ° | 12/9/2004 | 3/1/2017 |

*All dimensions are in inches.

RoHS COMPLIANCE:

15-266-1-XX

| PART NUMBER | RoHS COMPLIANT |
|--------------|----------------|
| 15-266-1-05 | NO |
| 15-266-1-088 | NO |
| 15-266-1-095 | NO |

15-266-2-XX

| PART NUMBER | RoHS COMPLIANT |
|--------------|----------------|
| 15-266-2-05 | NO |
| 15-266-2-088 | NO |
| 15-266-2-095 | NO |

15-266-3-XX

| PART NUMBER | RoHS COMPLIANT |
|--------------|----------------|
| 15-266-3-05 | NO |
| 15-266-3-088 | NO |
| 15-266-3-095 | NO |

15-266-4-XX

| PART NUMBER | RoHS COMPLIANT |
|--------------|----------------|
| 15-266-4-05 | NO |
| 15-266-4-088 | NO |
| 15-266-4-095 | NO |

MILITARY REFERENCE SPECIFICATIONS:

15-266-1-XX

| PART NUMBER | MIL SPECIFICATION | MIL PART NUMBER | COMMERCIAL ITEM DESCRIPTION (CID) SPECIFICATION | CID PART NUMBER |
|--------------|-------------------|---------------------------|---|-------------------------------|
| 15-266-1-05 | MIL-T-55155/12 | M55155/12XH10 (SE12XC10S) | A-A-59126/12 | AA59126/12XH10 |
| 15-266-1-088 | MIL-T-55155/12 | M55155/12XJ10 | A-A-59126/12 | AA59126/12XJ10 (AA59126/1210) |
| 15-266-1-095 | MIL-T-55155/12 | M55155/12XI10 | A-A-59126/12 | AA59126/12XI10 |

15-266-2-XX

| PART NUMBER | MIL SPECIFICATION | MIL PART NUMBER | COMMERCIAL ITEM DESCRIPTION (CID) SPECIFICATION | CID PART NUMBER |
|-------------|-------------------|---------------------------|---|-----------------|
| 15-266-2-05 | MIL-T-55155/12 | M55155/12XH11 (SE12XC11S) | A-A-59126/12 | AA59126/12XH11 |

Continued on next page...

MILITARY REFERENCE SPECIFICATIONS CONTINUED:

15-266-2-XX

| PART NUMBER | MIL SPECIFICATION | MIL PART NUMBER | COMMERCIAL ITEM DESCRIPTION (CID) SPECIFICATION | CID PART NUMBER |
|--------------|-------------------|-----------------|---|-------------------------------|
| 15-266-2-088 | MIL-T-55155/12 | M55155/12XJ11 | A-A-59126/12 | AA59126/12XJ11 (AA59126/1211) |
| 15-266-2-095 | MIL-T-55155/12 | M55155/12XI11 | A-A-59126/12 | AA59126/12XI11 |

15-266-3-XX

| PART NUMBER | MIL SPECIFICATION | MIL PART NUMBER | COMMERCIAL ITEM DESCRIPTION (CID) SPECIFICATION | CID PART NUMBER |
|--------------|-------------------|---------------------------|---|-------------------------------|
| 15-266-3-05 | MIL-T-55155/12 | M55155/12XH12 (SE12XC12S) | A-A-59126/12 | AA59126/12XH12 |
| 15-266-3-088 | MIL-T-55155/12 | M55155/12XJ12 | A-A-59126/12 | AA59126/12XJ12 (AA59126/1212) |
| 15-266-3-095 | MIL-T-55155/12 | M55155/12XI12 | A-A-59126/12 | AA59126/12XI12 |

15-266-4-XX

| PART NUMBER | MIL SPECIFICATION | MIL PART NUMBER | COMMERCIAL ITEM DESCRIPTION (CID) SPECIFICATION | CID PART NUMBER |
|--------------|-------------------|---------------------------|---|-------------------------------|
| 15-266-4-05 | MIL-T-55155/12 | M55155/12XH13 (SE12XC13S) | A-A-59126/12 | AA59126/12XH13 |
| 15-266-4-088 | MIL-T-55155/12 | M55155/12XJ13 | A-A-59126/12 | AA59126/12XJ13 (AA59126/1213) |
| 15-266-4-095 | MIL-T-55155/12 | M55155/12XI13 | A-A-59126/12 | AA59126/12XI13 |

TOOLING:

| INSTALLATION TOOL: ARBOR PRESS | INSTALLATION TOOL: ANVIL (ARBOR PRESS OPERATED) | INSTALLATION TOOL: PRESS-FIT / ROLL SWAGE / RIVET PUNCH (ARBOR PRESS OPERATED) | INSTALLATION TOOL: FLARE SWAGE PUNCH (ARBOR PRESS OPERATED) |
|-----------------------------------|---|--|---|
| TM1 | TA94-62-20 | TP62-44 | TFLP90-150 |

NOTES:

| |
|------------------------|
| DATASHEET NOTES |
|------------------------|

N/A

| |
|--------------------------|
| INSTRUCTION NOTES |
|--------------------------|

SEE GENERAL SWAGING INSTALLATION INSTRUCTION ON CONCORD ELECTRONICS' WEBSITE WWW.CONCORD-ELECTRONICS.COM