

D9 - SERIES

SPECIFICATIONS AND ORDERING INFORMATION

2 5/16" DIAMETER 1.5 AMPS @ 28 VDC

The D9 Series has a 15° index with a maximum of 24 positions. Indexing is provided by a dual-ball hill and valley design. Standard features include solder lug terminals, adjustable stops and glass epoxy insulation.



SPECIFICATIONS

ELECTRICAL

Current and Voltage Rating: Make and break resistive load 1.5 amps @ 28 VDC; 0.25 amp @ 115 VAC.
Current Carrying Capacity: 9 amps.
Dielectric Strength: 1,000 VAC between current carrying parts and ground.
Contact Resistance: Average initial 5 milliohms.
Insulation Resistance: In excess of 750,000 megohms.

Hardware: Mounting nut and lockwasher are shipped assembled.

MECHANICAL

Materials and Finishes: All parts utilize non-corrosive materials as standard.
Clips and Rotors: Brass with silver plate as standard.
Insulation: Glass epoxy.
Index: Dual-ball, hill and valley design.
Index Life: 25,000 cycles minimum.
Index Torque: Switches have lowest practical torque consistent with crisp detenting and smooth, reliable operation.
Index Angles: Positive 15° standard.
Index Stops: Adjustable standard, fixed or continuous.
Stop Strength: 25 in. lbs. minimum.

STANDARD PART NUMBER

GLASS EPOXY INSULATION SWITCHES - 15° INDEXING
 ADJUSTABLE STOPS - SOLDER LUG TERMINALS - STOPS SET @ 2 POS.

POLES	ACTIVE POSITIONS	POLES/ SECTION	NO. OF SECTIONS	SHORTING	NON-SHORTING	FIG. *
01	02-23	1	1	D9G0123S	D9G0123N	DU
02	02-23	1	2	D9G0223S	D9G0223N	DU
03	02-23	1	3	D9G0323S	D9G0323N	DU
04	02-23	1	4	D9G0423S	D9G0423N	DU
05	02-23	1	5	D9G0523S	D9G0523N	DU
06	02-23	1	6	D9G0623S	D9G0623N	DU
07	02-23	1	7	D9G0723S	D9G0723N	DU
08	02-23	1	8	D9G0823S	D9G0823N	DU

* FIGURES ARE SHOWN ON PAGE 57.

DIMENSIONS

STANDARD CONSTRUCTION
 D9G - GLASS EPOXY
 CONSTRUCTION

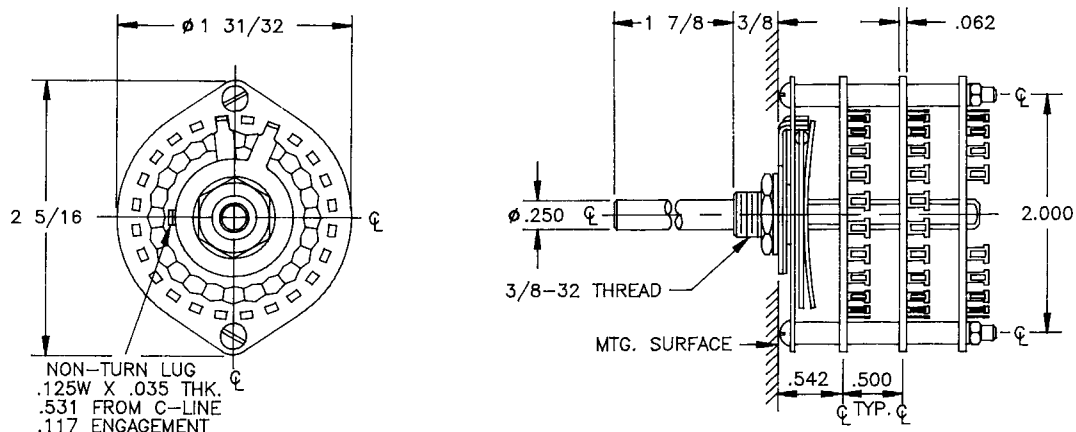

How to Order Additional Options:

2 DIGIT SERIES	INSULATION TYPE	TOTAL POLES	ACTIVE POSITIONS	CONTACT TYPE	TERMINAL TYPE	INDEX ANGLE	STOP TYPE	SHAFT/ BUSHING	SHAFT FLAT
D9	G - GLASS	01 - MIN.	24 - MAX @ 15°	S - SHORTING N - NON SHORTING	L - SOLDER LUG R - REAR P.C.		A - ADJ. F - FIXED C - CONT.	SEE CHART "A"	SEE CHART "B"

CUSTOMERS SPECIFIED ORDER NUMBER FOR STANDARD OPTIONS

D	9	G	<input type="text"/>	<input type="text"/>	<input type="checkbox"/>	<input type="checkbox"/>	<input type="checkbox"/>	<input type="checkbox"/>	<input type="checkbox"/>
			(SPECIFY)	(SPECIFY)	(SPECIFY)	(SPECIFY)	(SPECIFY)	(SPECIFY)	(SPECIFY)

ADDITIONAL OPTIONS

SHAFT, BUSHING, AND FLAT OPTIONS

P/N OPT.	SHAFT LGTH. "A"	BUSH. LGTH. "B"
01	3/8	1/4
02	3/8	3/8
03	1/2	1/4
04	1/2	3/8
05	9/16	1/4
06	9/16	3/8
07	3/4	1/4
08	3/4	3/8
09	1	1/4
10	1	3/8
11	1 1/2	1/4
12	1 1/2	3/8
13	1 7/8	1/4
14	1 7/8	3/8

P/N OPT.	FLAT ANGLE
B	ROUND - STD
U	7.5°
W	172.5°
Y	187.5°
Z	352.5°

SHAFT AS VIEWED WITH NON-TURN LUG AT 9 O'CLOCK AND SHAFT IN EXTREME CCW POSITION AND STRUT BOLTS ORIENTED VERTICALLY.

PRINTED CIRCUIT BOARD OPTIONS

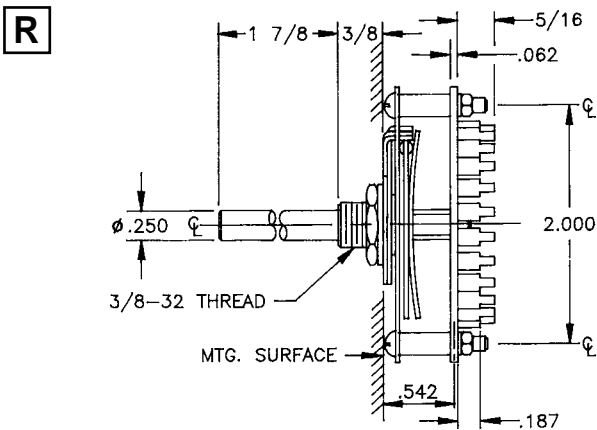

P.C. BOARD MOUNTING PATTERN

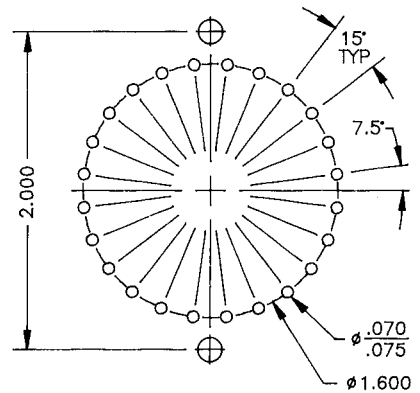

CUSTOM SWITCHES ARE AVAILABLE. CONTACT THE FACTORY WITH YOUR COMPLETE SPECIFICATIONS.