

Metric Spacers

Clearance Spacers

- Standard lengths available from 3 to 30mm.
- Brass spacers: base material is free-machining brass, with nickel plating.
- Aluminium spacers: supplied with a clear passivation finish to prevent oxidation.
- Plastic material: Nylon 66 UL94V-2.



CLEARANCE FOR M3 THREAD

Materials

Base material: Brass, Aluminium or Plastic

Finish

Brass: Nickel
Aluminium: Clear Passivate

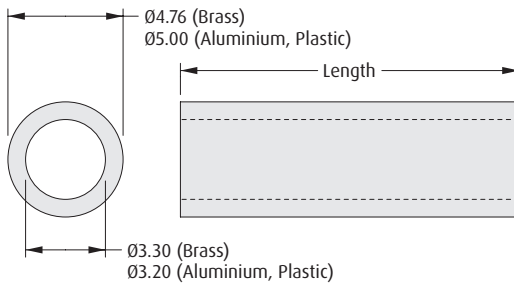

CLEARANCE FOR M4 THREAD

Materials

Base material: Brass or Plastic

Finish

Brass: Nickel

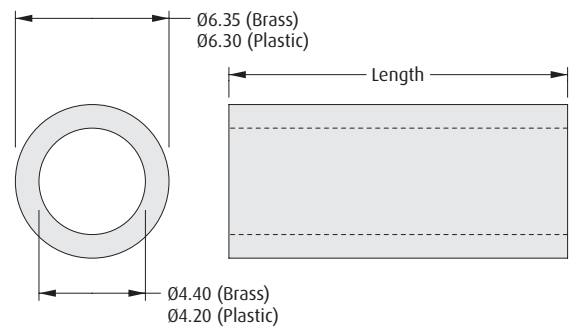

HOW TO ORDER

R30 - 6 XX XX XX

SERIES CODE

MATERIAL

01	Brass
20	Aluminium
70	Plastic

LENGTH (mm)

03 to 16, 18, 20, 25, 30	Brass, Aluminium
03 to 16, 18, 20, 25	Plastic

FINISH

02	Nickel (Brass only)
14	Passivation (Aluminium only)
94	White (Plastic only)

HOW TO ORDER

R40 - 6 XX XX XX

SERIES CODE

MATERIAL

00	Brass
71	Plastic

LENGTH (mm)

03 to 16, 18, 20, 25, 30	Brass
03, 05 to 08, 10 to 12, 15, 18	Plastic

FINISH

02	Nickel (Brass only)
94	White (Plastic only)

All dimensions in mm.