

Customer Information Sheet

DRAWING No.: S8081-46R

SHEET 2 OF 2

IF IN DOUBT - ASK

©

NOT TO SCALE

THIRD ANGLE PROJECTION

ALL DIMENSIONS IN mm

- NOTES:
1. THIS PRODUCT IS RECOMMENDED FOR USE WITH S07-46 AND S08-46 LED BRIDGE PINS.
 2. ALL PRODUCT IS RoHS AND REACH COMPLIANT.
 3. PRODUCT IS TAPE AND REELED IN GENERAL ACCORDANCE WITH EIA-481-2 (ELECTRONICS INDUSTRIES ASSOCIATION).
 4. PACKAGING = 10,000 COMPONENTS PER REEL.

SPECIFICATION:

MATERIAL:
CONTACT = STAINLESS STEEL, 0.10mm THICK
FINISH:
1.0μ - 3.0μ TIN OVER 0.4μ - 1.5μ NICKEL

ELECTRICAL:
CURRENT RATING = 1.5A
VOLTAGE RATING = 250V AC/DC

MECHANICAL:
INSERTION FORCE = 12N MAX (INITIAL)
WITHDRAWAL FORCE = 4N MIN (INITIAL)
DURABILITY = 10 CYCLES MAX

ENVIRONMENTAL:
OPERATING TEMPERATURE = -40°C TO +85°C

SOLDERING DATA:
SOLDERING HEAT RESISTANCE = 260°C FOR 10 SECONDS MAX

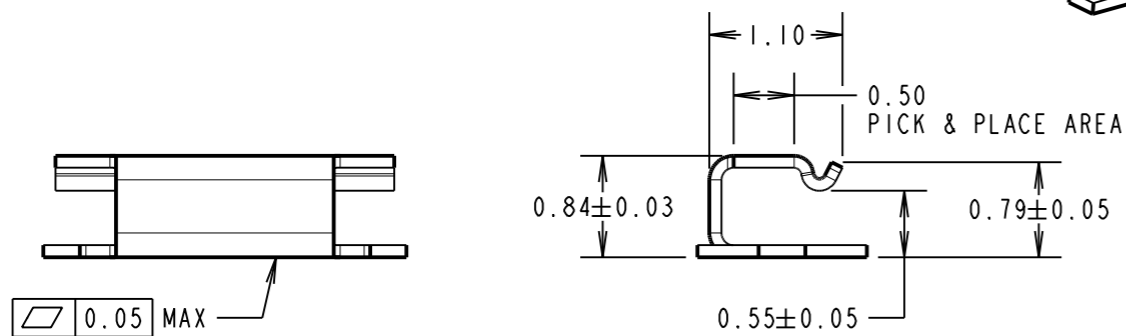
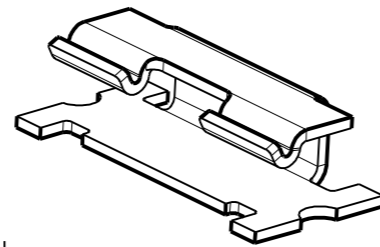
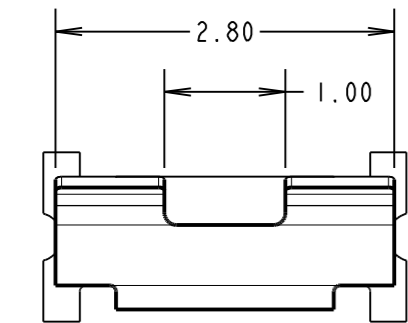
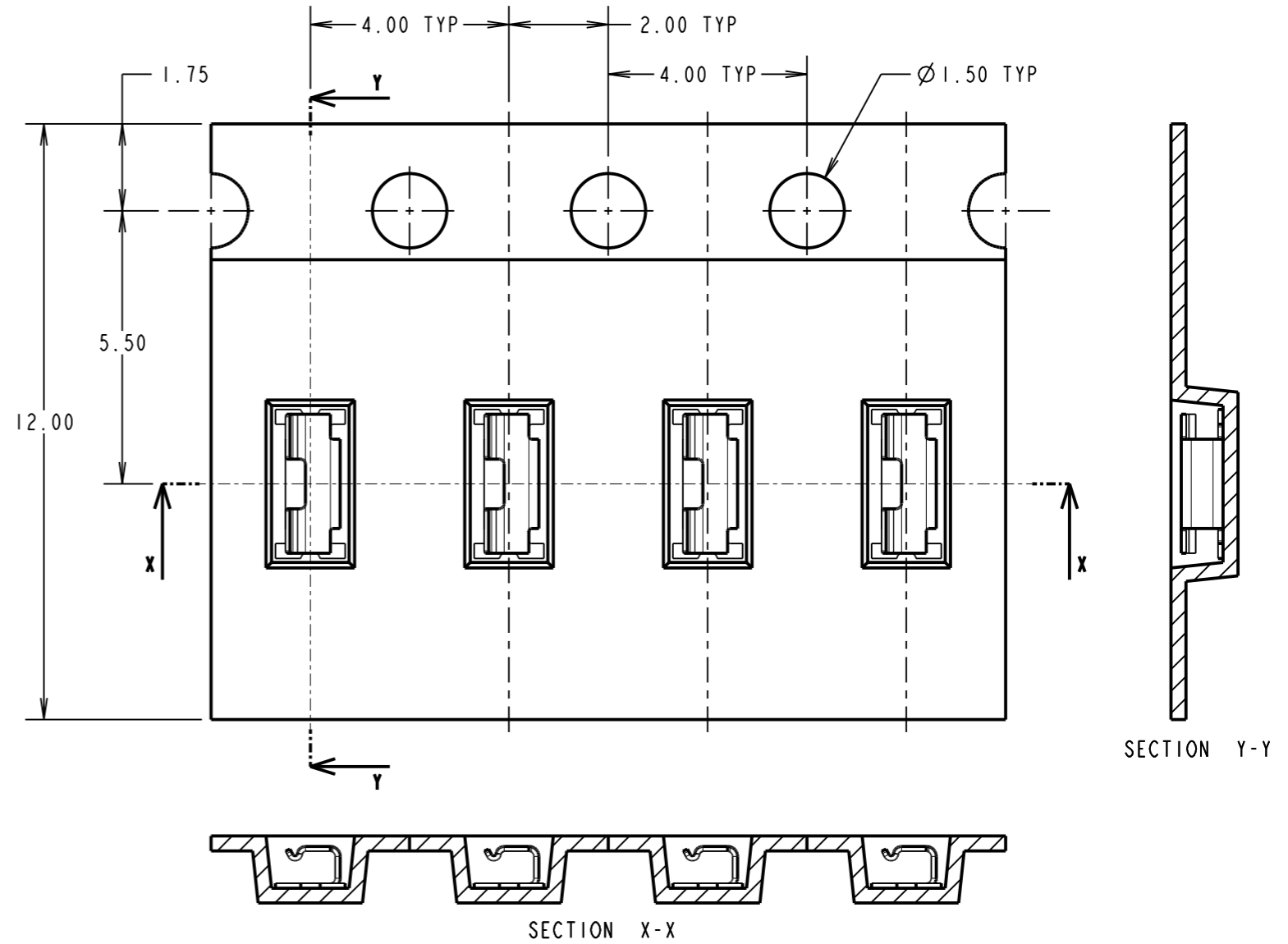
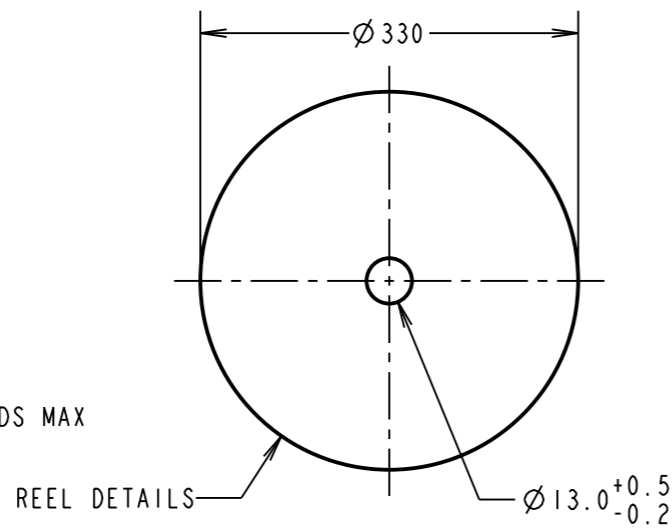

COMPONENT DETAILS

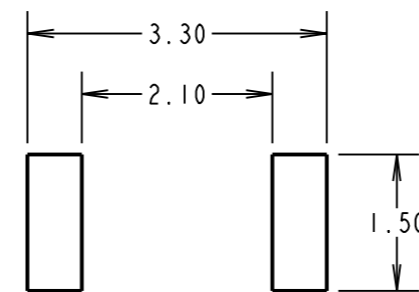
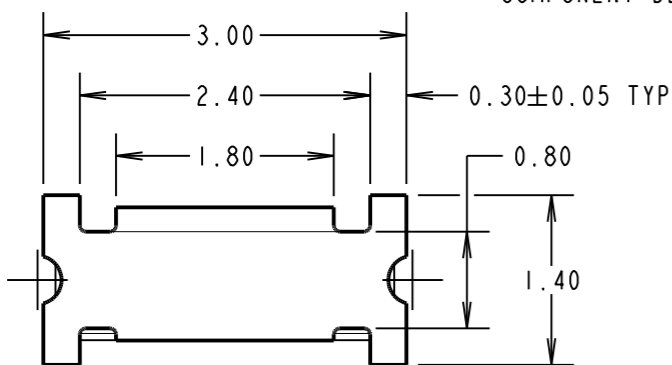

RECOMMENDED PCB LAYOUT
(TOLERANCE = ±0.05)

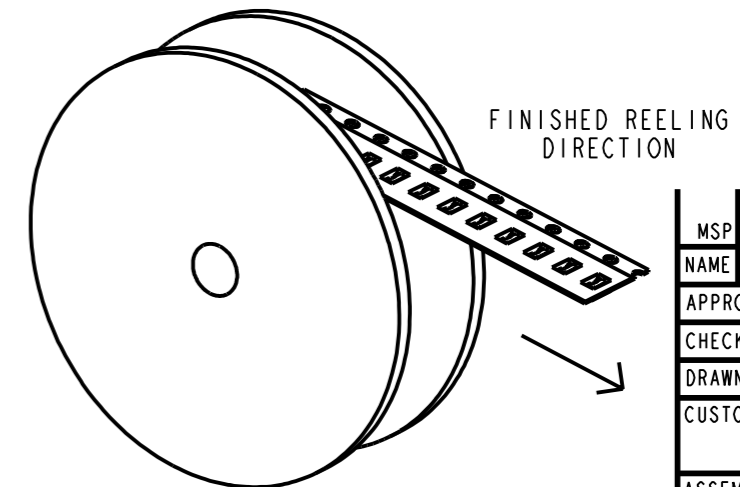

MSP	3	04.11.15	13155
NAME	ISS.	DATE	C/NOTE
APPROVED:		M. PERREN	
CHECKED:		S. BENNETT	
DRAWN:		S. BENNETT	
CUSTOMER REF.:			
ASSEMBLY DRG:			

HARWIN

www.harwin.com
technical@harwin.com

THIS DRAWING AND ANY INFORMATION OR DESCRIPTIVE MATTER SET OUT HEREON ARE CONFIDENTIAL AND COPYRIGHT PROPERTY OF THE HARWIN GROUP AND MUST NOT BE DISCLOSED, LOANED, COPIED OR USED FOR MANUFACTURING, TENDERING OR FOR ANY OTHER PURPOSE WITHOUT THEIR WRITTEN PERMISSION.

TOLERANCES

X. = ±1mm
X.X = ±0.50mm
X.XX = ±0.10mm
X.XXX = ±0.01mm
ANGLES = ±5°
UNLESS STATED

MATERIAL:

SEE ABOVE

FINISH: SEE ABOVE

S/AREA:

mm²

TITLE: HORIZONTAL SMT CABLE AND PIN CLIP

DRAWING NUMBER:

S8081-46R

SHT 2 OF 2