

# 8312/12HL-118 - DC Axial Fan

80mm axial fan with high air flow. The DC drive employs an electronically commutated external rotor motor with high efficiency. Drive electronics is completely integrated into the fan hub. The air flow and noise level can be controlled by varying the supply voltage range.



## Features

- Electronic locking protection is integrated into the fan circuit. A PTC resistor protects against overloading; restarting occurs after a switchoff time of approximately 15 seconds.
- Electronic reverse polarity protection. Fan starts only with correct polarity.
- TTL logic square wave sensor signal for speed monitoring (2 pulses per revolution).
- Extremely low EMI.
- Electrical connection via 3 leads AWG22, length 460mm +/- 10mm

## General Data

Nominal voltage	V DC	12
Voltage range	V DC	6 ... 15
Nominal speed	min <sup>-1</sup>	4200
Max. flow rate (curve 4)	m <sup>3</sup> /h	67
Max. flow rate (curve 4)	CFM	39
Noise in optimum operating range	bels	5.8
Noise free air	dB(A)	43
Current consumption	mA	325
Power consumption	W	3.9
Permanent ambient temperature at max. voltage	°C	-20 ... +75
Service life (75 °C)	h	27.500
Service life (40 °C)	h	62.500
Approvals	UL, CSA, VDE	
Fan housing / impeller	PBTP / PA 6.6	
Bearing system	ball bearing	
Mass	kg	0,170

All data are mean values at nominal conditions.

Subject to change without notice

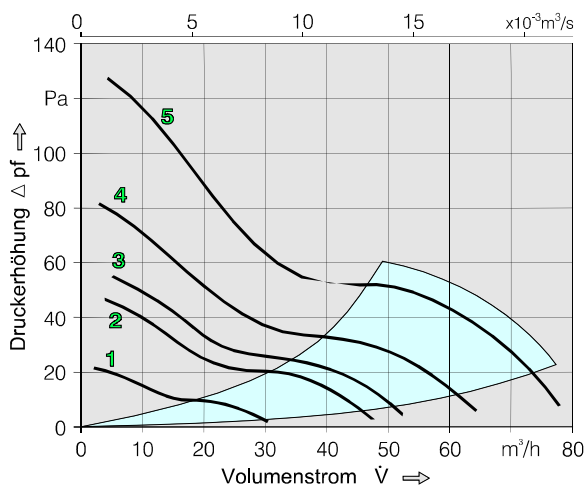

Fan drawing see below: 929 4303 118.

# Tacho Signal

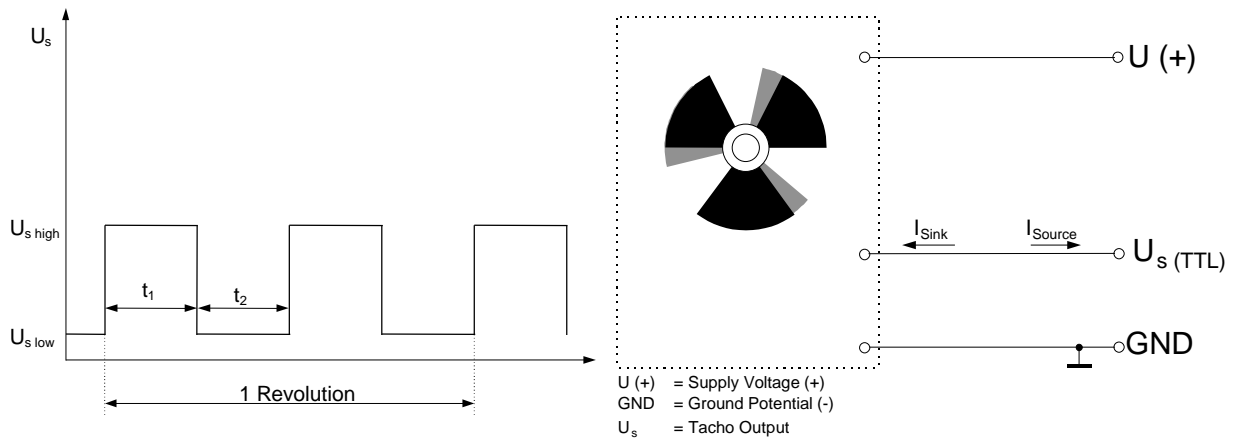

Tacho Output	2 pulses per revolution
$U_s \text{ high}$	2.5 ... 5.5 V DC at $I_{\text{source}} = 1 \text{ mA}$
$U_s \text{ low}$	$\leq 0,4 \text{ V DC}$ at $I_{\text{sink}} = 1 \text{ mA}$
$I_{\text{sink max}}$	= 5 mA
$t_1 / t_2$	0,8 - 1,2

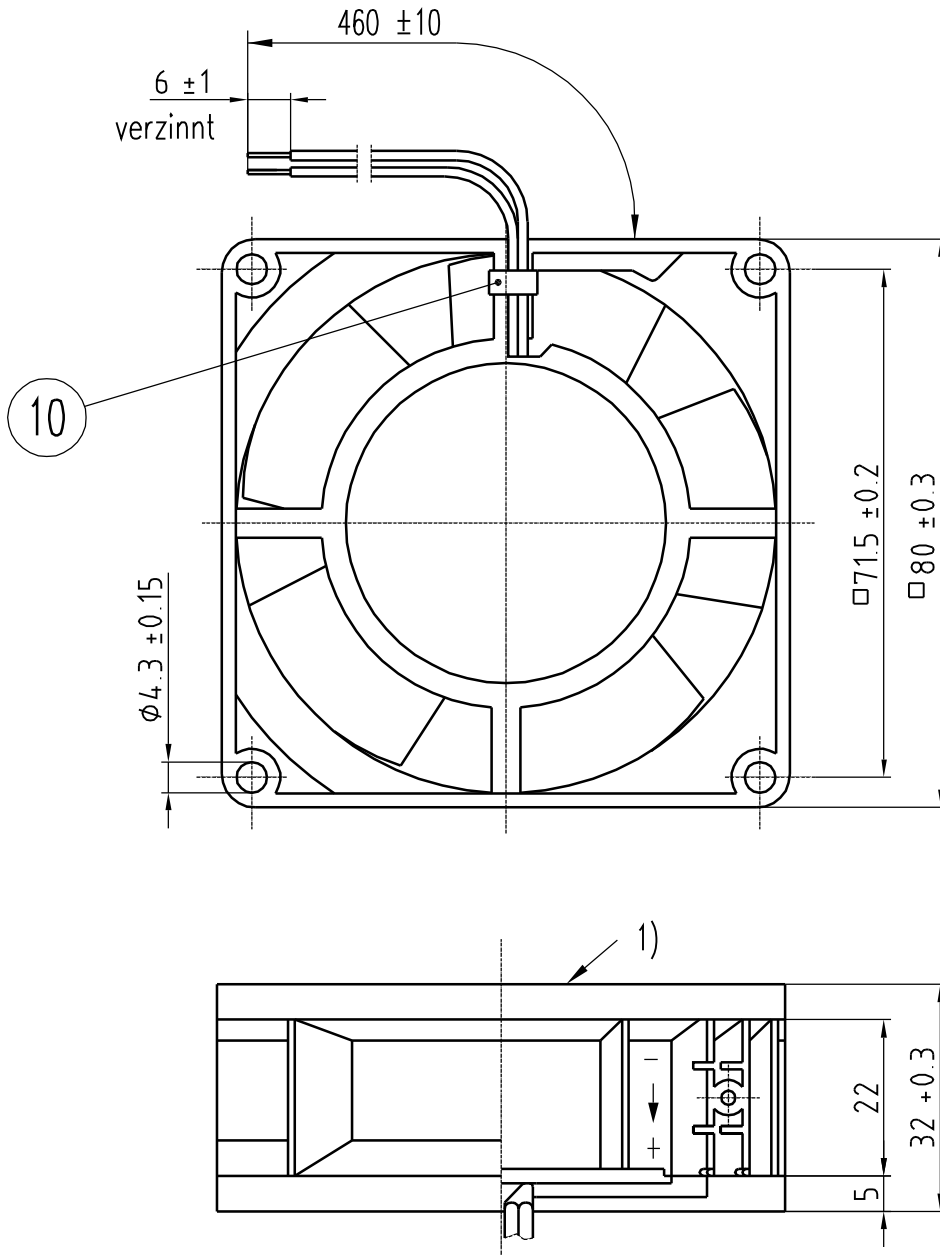

1) Rotorüberstand bis max. 0.4 zulässig  
 Axialspiel: (K) mit Feder ausgeglichen  
 (G) 0.1–0.5 mm

Tolerierung Allgemeintoleranzen:		DIN 7167			
AutoCAD 14				Artikel	
Bearbeitet	Datum			Axiallüfter	
	09.09.1998	Name		1:1	
	-	Koletzki M.			
	-	000000098642			
	Index	Aend.-Nr.			
Geprüft u. zur Verwendung freigegeben von KOLETZKI am 18.08.2003		<b>PAPST</b> PAPST-MOTOREN GmbH & Co KG D-78112 St. Georgen Germany		Zchg.-Nr.	9294303118
				Ers.f.Zchg.	A4